



RECYCLED LANDSCAPE EDGING



epicplastics.com

DEFINE YOUR DESIGN

Professionally installed or Do-it-Yourself, our edging solutions give your outdoor design a professional and manicured finish.

TABLE OF CONTENTS

| | |
|---------------------|----|
| OUR MISSION | 04 |
| BENDA BOARD | 06 |
| EPIC EDGE | 10 |
| EDGE EX | 14 |
| TURF EDGE | 16 |
| ACCESSORIES | 20 |
| OUR RECYCLING STORY | 22 |





OUR MISSION

Epic Plastics sets the standard in quality landscape edging products, making them exclusively from recycled plastics. Our products continue to be the professional landscaper's choice for high-quality edging solutions and are widely used in the do-it-yourself market as well.

Epic Plastics' commitment to our environment is crucial to our success and sets us apart from our competition. Our products are made from recycled plastic feedstock. Those milk, shampoo, and laundry detergent bottles you put out on the curb for recycling, are the materials that make Epic Plastics' products!

Our commitment to manufacturing environmentally friendly products doesn't stop at recycling, we also don't burn fuels to make our products. Epic Plastics' equipment is powered by electricity and releases zero carbon emissions during the manufacturing process. Today, we've saved over 200 million pounds of post-consumer plastic from landfills and continue the journey to a sustainable future. All of Epic's edging products are LEED approved giving your project the boost it needs to go from Gold to Platinum!

PROUDLY MADE IN THE USA EXCLUSIVELY WITH RECYCLED PLASTIC



EXPERIENCE **EPIC** | RECYCLED LANDSCAPE EDGING

Epic Plastics products continue to be the professional landscaper's choice for high-quality edging solutions and are widely used in the do-it-yourself market as well.



CUSTOMER SERVICE

Contact Cindy Rhed
Email: crhed@epicplastics.com
Phone: 209-365-2122



RESOURCES

Technical Documents:
epicplastics.com/document-library
Installation Videos:
epicplastics.com/video-library



Files are available for download at
CADdetails.com



BENDA BOARD® | REDWOOD/3.47 CM

PRODUCT SPECS

Versatile, Easy-to-Install | Flexible & Durable | Slip Joint | 4 Popular Colors | Non-Structural Uses

| PRODUCT # | PRODUCT COLOR | AVAILABLE SIZES (Metric / Actual / Nominal Size) | MIN. ORDER |
|-----------|---------------|--|------------------------|
| 100036729 | Redwood | 1.82 cm x 8.5 cm x 6.04 m (.72 in x 3.35 in x 19 ft 10 in / 1x4x20) | 120 pcs-2,400 ft/ lift |
| 100036731 | Redwood | 3.47 cm x 8.63 x 6.04 m (1.37 in x 3.4 in x 19 ft 10 in / 2x4x20) | 60 pcs-1,200 ft / lift |
| 100036730 | Redwood | 1.65 cm x 13.58 cm x 6.04 m (.65 in x 5.35 in x 19 ft 10 in / 1X6X20) | 80 pcs-1,600 ft / lift |
| 100036732 | Redwood | 3.42 cm x 13.71 cm x 4.82 m (1.35 in x 5.4 in x 15 ft 10 in / 2X6X16) | 40 pcs- 640 ft/ lift |
| 100059386 | Teak | 1.82 cm x 8.5 cm x 6.04 m (.72 in x 3.35 in x 19 ft 10 in / 1x4x20) | 100 pcs-2,000 ft/ lift |
| 100059389 | Teak | 3.47 cm x 8.63 x 6.04 m (1.37 in x 3.4 in x 19 ft 10 in / 2x4x20) | 50 pcs-1,000 ft / lift |
| 100059387 | Teak | 1.65 cm x 13.58 cm x 6.04 m (.65 in x 5.35 in x 19 ft 10 in / 1X6X20) | 100 pcs-2,000 ft/ lift |
| 100036733 | Sand | 1.82 cm x 8.5 cm x 6.04 m (.72 in x 3.35 in x 19 ft 10 in / 1x4x20) | 120 pcs-2,400 ft/ lift |
| 100051993 | Black | 1.82 cm x 8.5 cm x 6.04 m (.72 in x 3.35 in x 19 ft 10 in / 1x4x20) | 120 pcs-2,400 ft/ lift |
| 100082778 | Black | 1.65 cm x 13.58 cm x 6.04 m (.65 in x 5.35 in x 19 ft 10 in / 1X6X20) | 80 pcs-1,600 ft / lift |

BENDA BOARD® | CREATE ORGANIC CURVES & SHAPES

Epic Plastics' BENDA BOARD® has become one of the most preferred edging solutions for both professional landscapers and homeowners. Made exclusively with recycled plastic, Benda Board provides a durable edging solution while retaining flexibility for creative landscape designs. Invented as a superior alternative to natural wood edging, Benda Board will not rot or splinter.

AVAILABLE COLORS:



REDWOOD

TEAK

SAND

BLACK

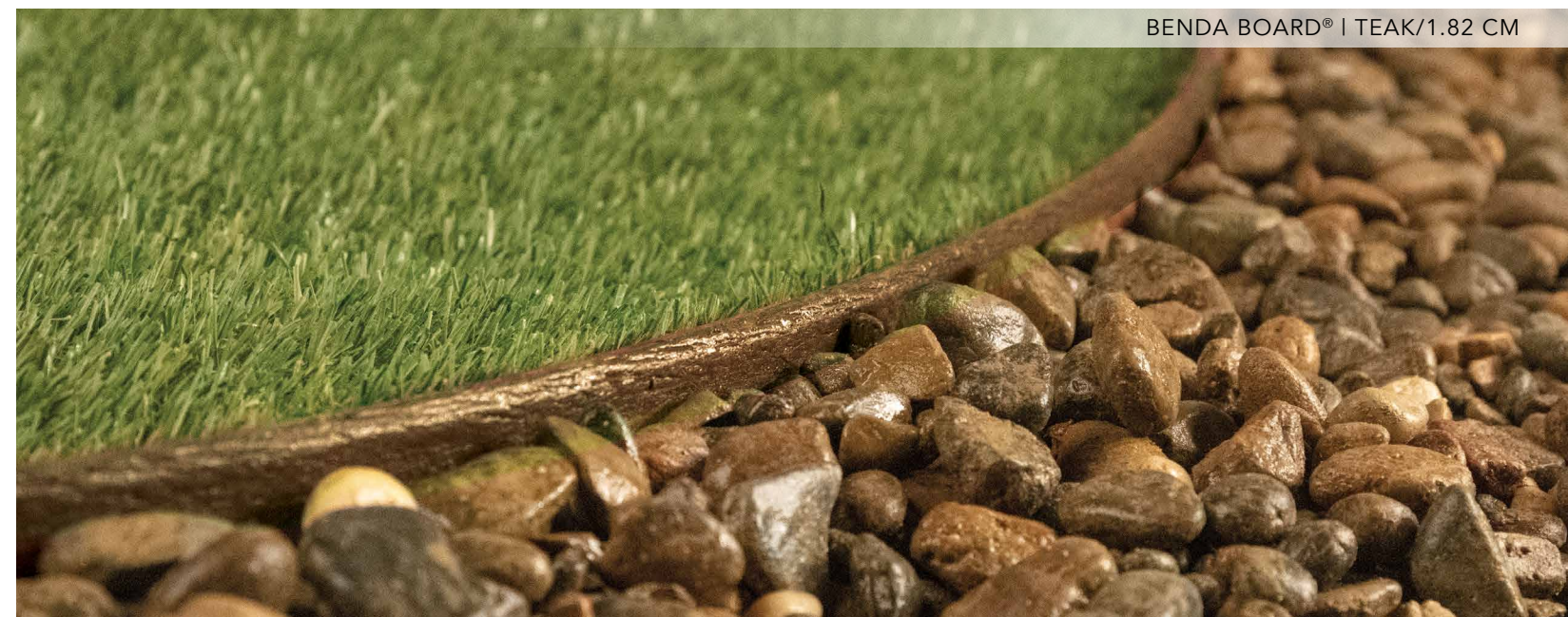

BENDA BOARD® | TEAK/1.82 CM

INSTALLATION INSTRUCTIONS

BENDA BOARD HEADER BOARD DETAIL # 110-A

BENDA BOARD IS INTENDED FOR NON-STRUCTURAL USE ONLY

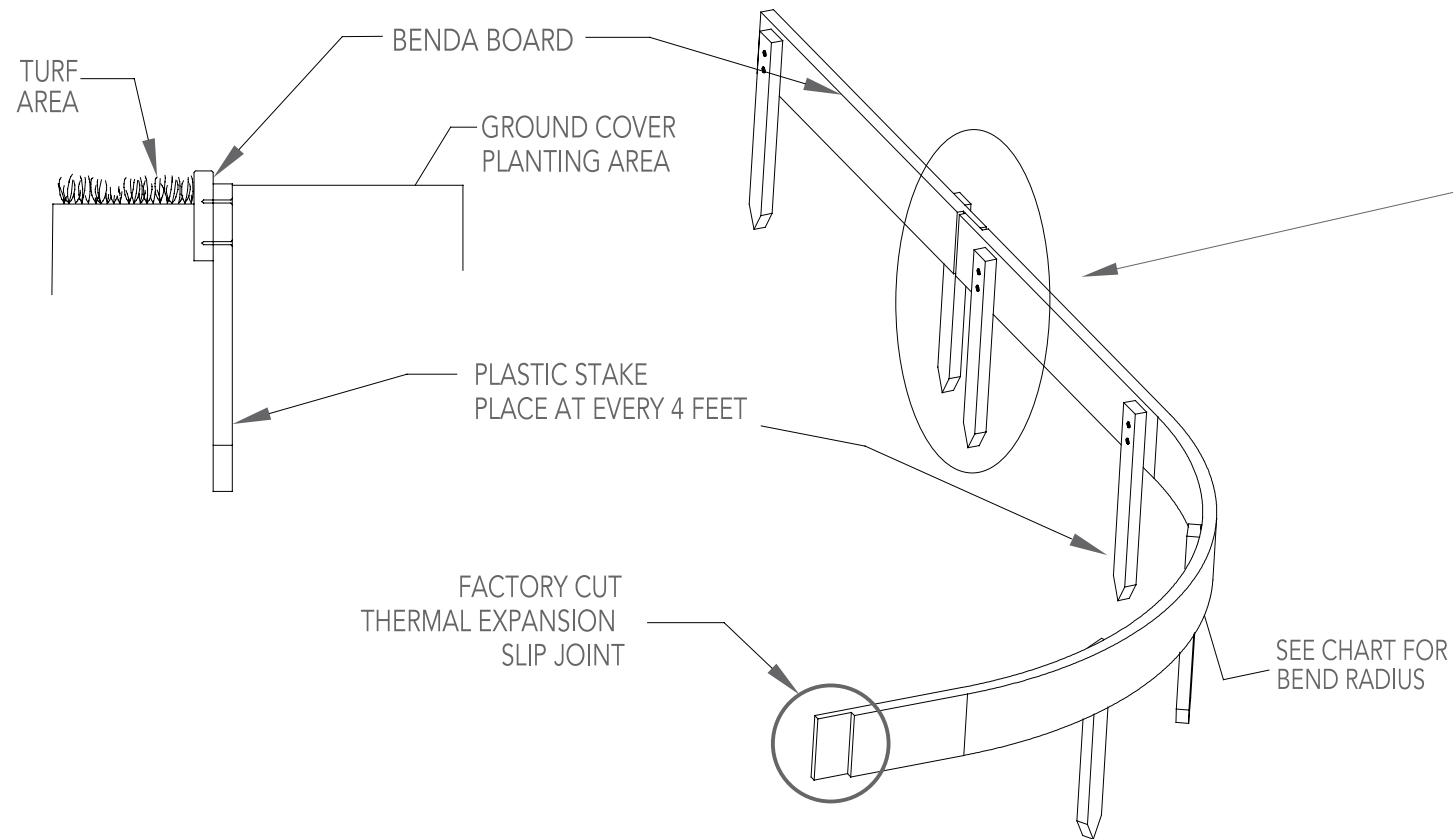

USE COURSE WOOD WORKING TOOLS FOR CUTTING AND DRILLING

ALLOW FOR THERMAL EXPANSION AND SHRINKAGE BY LEAVING GAPS BETWEEN END OF BOARDS

USE PLATED SCREWS TO JOIN BOARD TO STAKE

DO NOT SCREW BOTH BOARDS TOGETHER

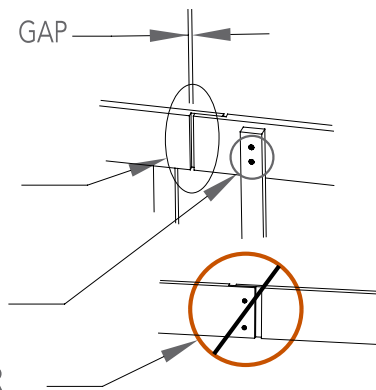

INSTALLATION INSTRUCTIONS

BENDA BOARD HEADER BOARD DETAIL # 110-A

BENDA BOARD IS INTENDED FOR NON-STRUCTURAL USE ONLY

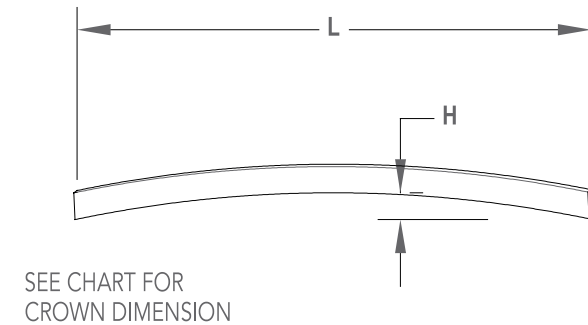
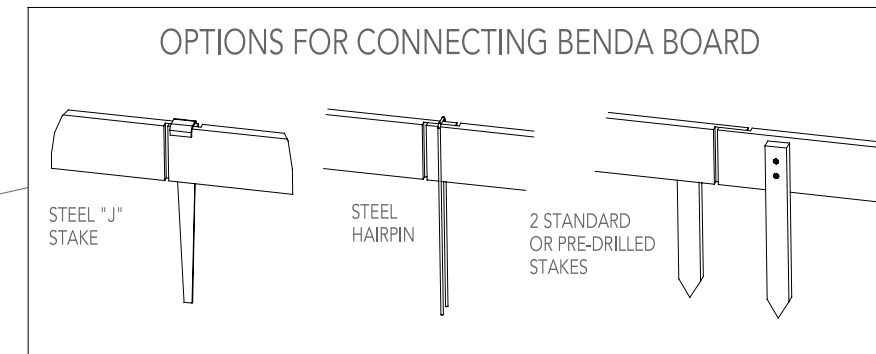

| NOMINAL DESCRIPTION | PRODUCT NUMBER | COLOR | ACTUAL DIMENSION D x H x L | MIN. BEND RADIUS | GAP | MAXIMUM CROWN H / L |
|---------------------|----------------|---------|--|------------------|-------------|------------------------|
| 1 x 4 x 20 | 100036729 | REDWOOD | .72in X 3.35in X 19ft 10in 1.82cm X 8.5cm X 6.04m | 24" | 1/4" - 1/2" | 19" / 20' |
| | 100036733 | SAND | | | | |
| | 100059386 | TEAK | | | | |
| | 100051993 | BLACK | | | | |
| 2 x 4 x 20 | 100036731 | REDWOOD | 1.37in X 3.4in X 19ft 10in 3.47cm X 8.63cm X 6.04m | 36" | 1/2" - 3/4" | 16" / 20' |
| | 100059389 | TEAK | | | | |
| 1 x 6 x 20 | 100036730 | REDWOOD | .65in X 5.35in X 19ft 10in 1.65cm X 13.58cm X 6.04m | 24" | 1/2" - 3/4" | 9" / 20' |
| | 100082778 | BLACK | | | | |
| | 100059387 | TEAK | | | | |
| 2 x 6 x 16 | 100036732 | REDWOOD | 1.35in X 5.4in X 15ft 10in 3.42cm X 13.71cm X 4.82m | 36" | 3/4" - 1" | N/A |

SEE PAGES 20-21 FOR RECOMMENDED ACCESSORIES



SCAN THE QR CODE TO WATCH OUR VIDEO FOR INSTALLATION INSTRUCTIONS AND OTHER IMPORTANT RESOURCES.

Made in USA by Epic Plastics
104 E. Turner Road, Lodi, CA 95240
209-333-6161 | epicplastics.com



EPIC EDGE® | CARMEL BROWN/1.40 CM

PRODUCT SPECS

Nominal Thermal Expansion | Straight Runs, Sweeping Curves | Natural Wood Grain
Limits Weed Migration

| PRODUCT # | AVAILABLE SIZES <small>(Metric / Actual / Nominal Size)</small> | MIN. ORDER |
|-----------|---|------------------------|
| 100041851 | 1.40 cm x 8.5 cm x 6.09 m <small>(.55 in x 3.35 in x 20 ft / 4x20)</small> | 120 pcs-2,400 ft/ lift |
| 100036756 | 1.40 cm x 13.58 cm x 6.09 m <small>(.55 in x 5.35 in x 20 ft / 6x20)</small> | 80 pcs-1,600 ft / lift |

EPIC EDGE® | CARMEL BROWN/1.40 CM



EPIC EDGE® | CREATE STRAIGHT RUNS & SWEEPING CURVES

Epic Plastics' Epic Edge® is a durable edging solution, which is made from high-density polyethylene recycled plastic & recycled wood flour. Sustainable and is ideal for creating straight runs and large sweeping curves in your landscaping.

AVAILABLE COLOR:



CARMEL BROWN

INSTALLATION INSTRUCTIONS

EPIC EDGE COMPOSITE HEADER BOARD DETAIL # 210-A

EPIC EDGE IS INTENDED FOR NON-STRUCTURAL USE ONLY

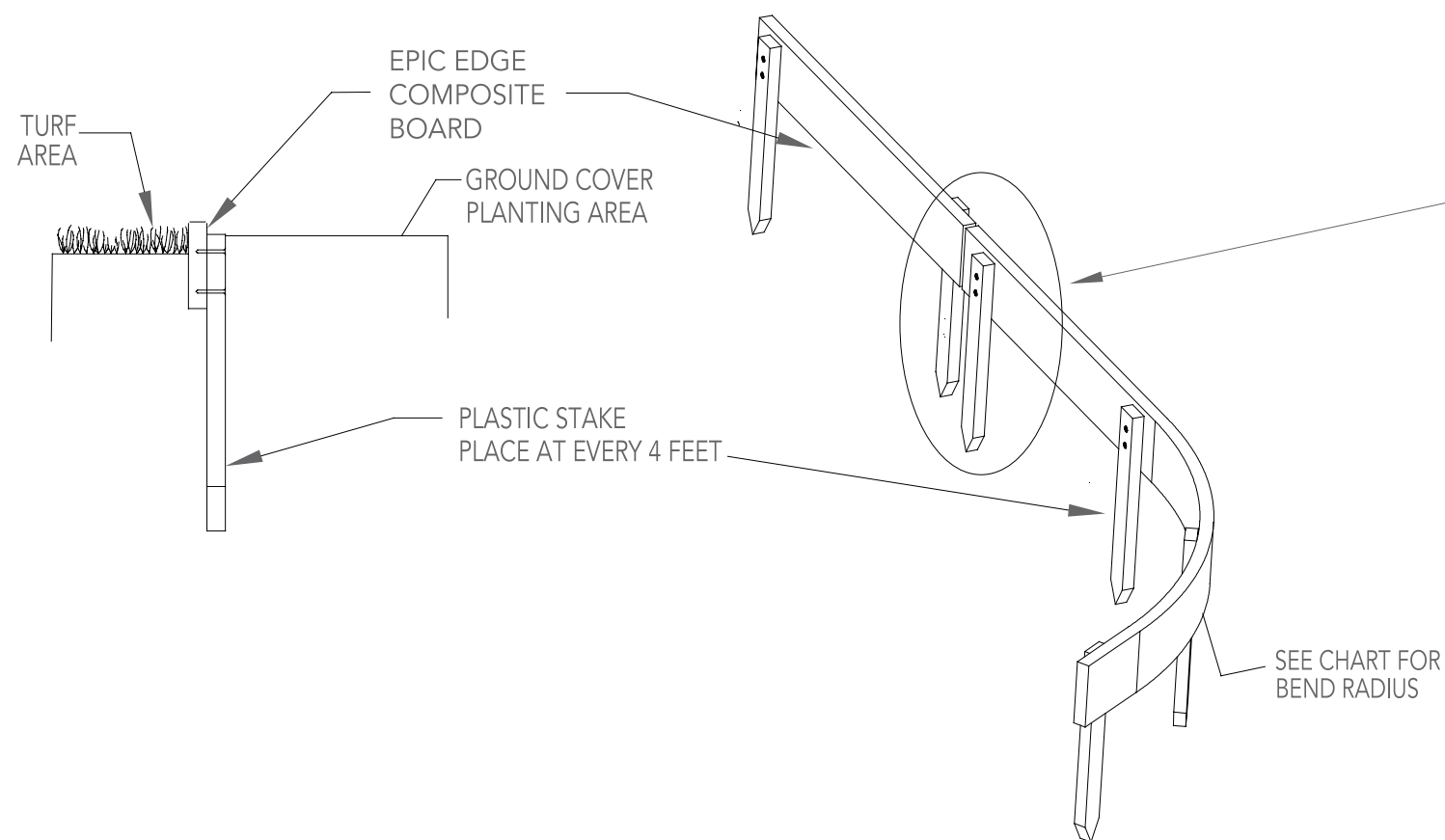

USE COURSE WOOD WORKING TOOLS FOR CUTTING AND DRILLING

ALLOW FOR THERMAL EXPANSION AND SHRINKAGE BY LEAVING GAPS BETWEEN END OF BOARDS

USE PLATED SCREWS TO JOIN BOARD TO STAKE

DO NOT SCREW BOTH BOARDS TOGETHER

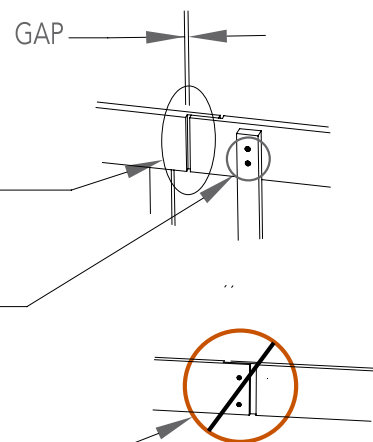

INSTALLATION INSTRUCTIONS

EPIC EDGE COMPOSITE HEADER BOARD DETAIL # 210-A

EPIC EDGE IS INTENDED FOR NON-STRUCTURAL USE ONLY

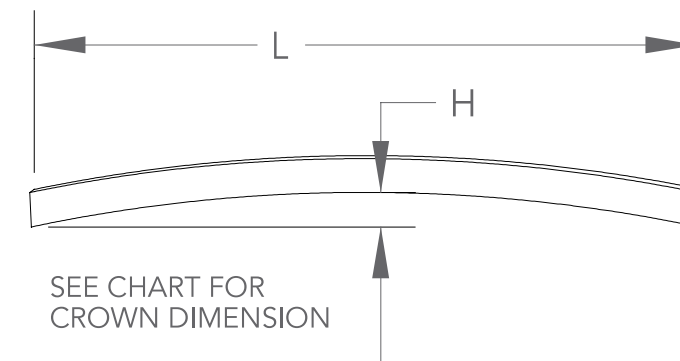
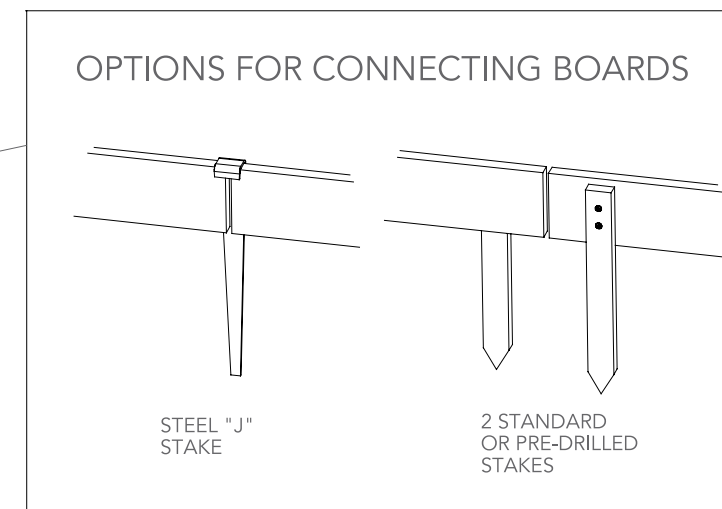

| PRODUCT NUMBER | NOMINAL DESCRIPTION | COLOR | ACTUAL DIMENSION D x H x L | MINIMUM RADIUS | GAP | MAXIMUM CROWN H / L |
|----------------|---------------------|--------------|--|----------------|------|------------------------|
| 100041851 | 4 X 20 | CARMEL BROWN | .55 in x 3.35 in x 20 ft 1.40cm x 8.5cm x 6.09m | 36" | 1/8" | 19 in / 20 ft |
| 100036756 | 6 X 20 | | .55 in x 5.35 in x 20 ft 1.40cm x 13.58cm x 6.09m | | | 9 in / 20 ft |

SEE PAGES 20-21 FOR RECOMMENDED ACCESSORIES



SCAN THE QR CODE TO WATCH OUR VIDEO FOR INSTALLATION INSTRUCTIONS AND OTHER IMPORTANT RESOURCES.

Made in USA by Epic Plastics
104 E. Turner Road, Lodi, CA 95240
209-333-6161 | epicplastics.com



EDGE EX® | BLACK/2.84 CM

INSTALLATION INSTRUCTIONS

EDGE EX BLACK TUBE EDGING DETAIL-415 A

EDGE EX IS INTENDED FOR NON-STRUCTURAL USE ONLY

EDGE EX® | FOR MAXIMUM FLEXIBILITY

Epic Plastics' Edge Ex® is a cost-effective durable edging solution, which is made from low-density polyethylene recycled plastic, and is a cost-effective solution for creating tight organic curves in your landscaping.

AVAILABLE COLOR:



BLACK

EDGE EX KIT



One Edge ex kit included with each 20' length of board

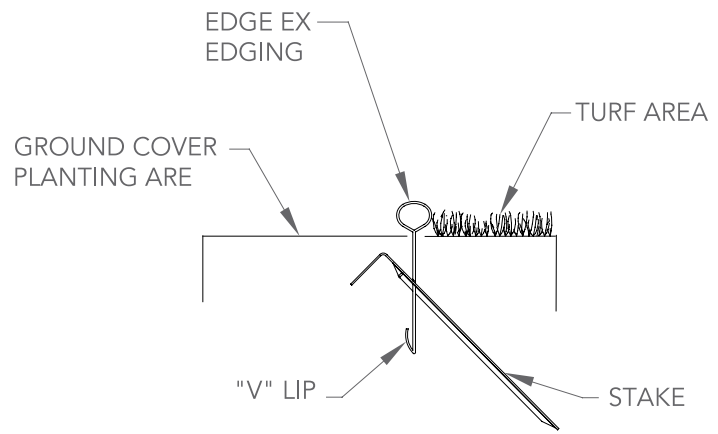

1. DIG A 4-5 INCH DEEP TRENCH ALONG EDGE OF LAWN.
2. PLACE EDGE EX EDGING INTO TRENCH. THE BOTTOM "V" LIP OF THE EDGING SHOULD BE FACING GROUND COVER OR PLANTING AREA.
3. POUND STAKE, PIERCING INTO EDGING AT A 45 DEGREE ANGLE. INSTALL STAKE EVERY 5 FEET (CLOSER AT CURVES).
4. FOLLOW STEPS 4A - 4D TO CONNECT EDGING.
5. FILL BACK TRENCH AND TAMP DOWN.

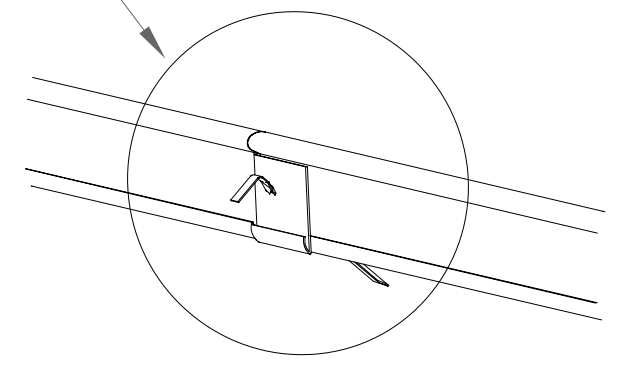
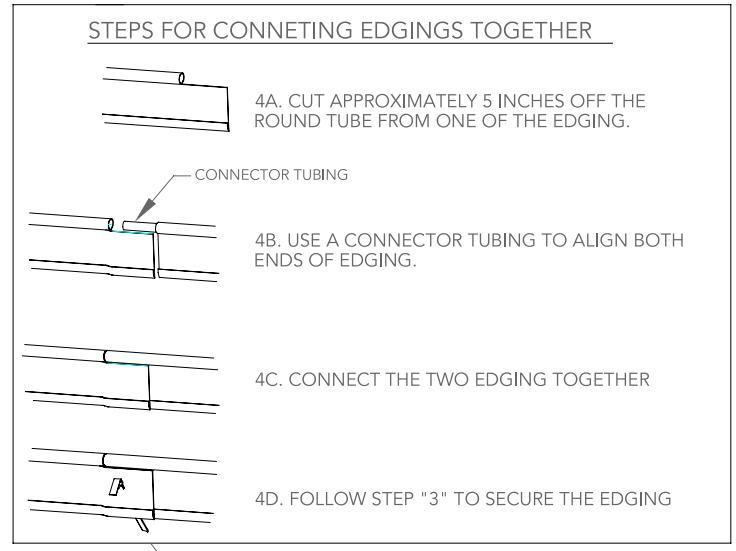

PRODUCT SPECS

| PRODUCT # | AVAILABLE SIZES (Metric / Actual / Nominal Size) | MIN. ORDER |
|-----------|---|------------------------|
| 100060052 | 2.84 cm x 13.2 cm x 6.09 m (1.12 in x 5.2 in x 20 ft / 5.5x20) | 200 pcs- 4000 ft /lift |
| 100059577 | One Coupler and Four Stakes | 50 cnt / box |

| PRODUCT NUMBER | NOMINAL DESCRIPTION | COLOR | ACTUAL DIMENSION D x H x L |
|----------------|---------------------|-------|--|
| 100060052 | 20' | BLACK | 1.12in X 5.2in X 20ft 2.84cm X 13.2cm x 6.09m |



SCAN THE QR CODE TO WATCH OUR VIDEO FOR INSTALLATION INSTRUCTIONS AND OTHER IMPORTANT RESOURCES.

Made in USA by Epic Plastics
104 E. Turner Road, Lodi, CA 95240
209-333-6161 | epicplastics.com

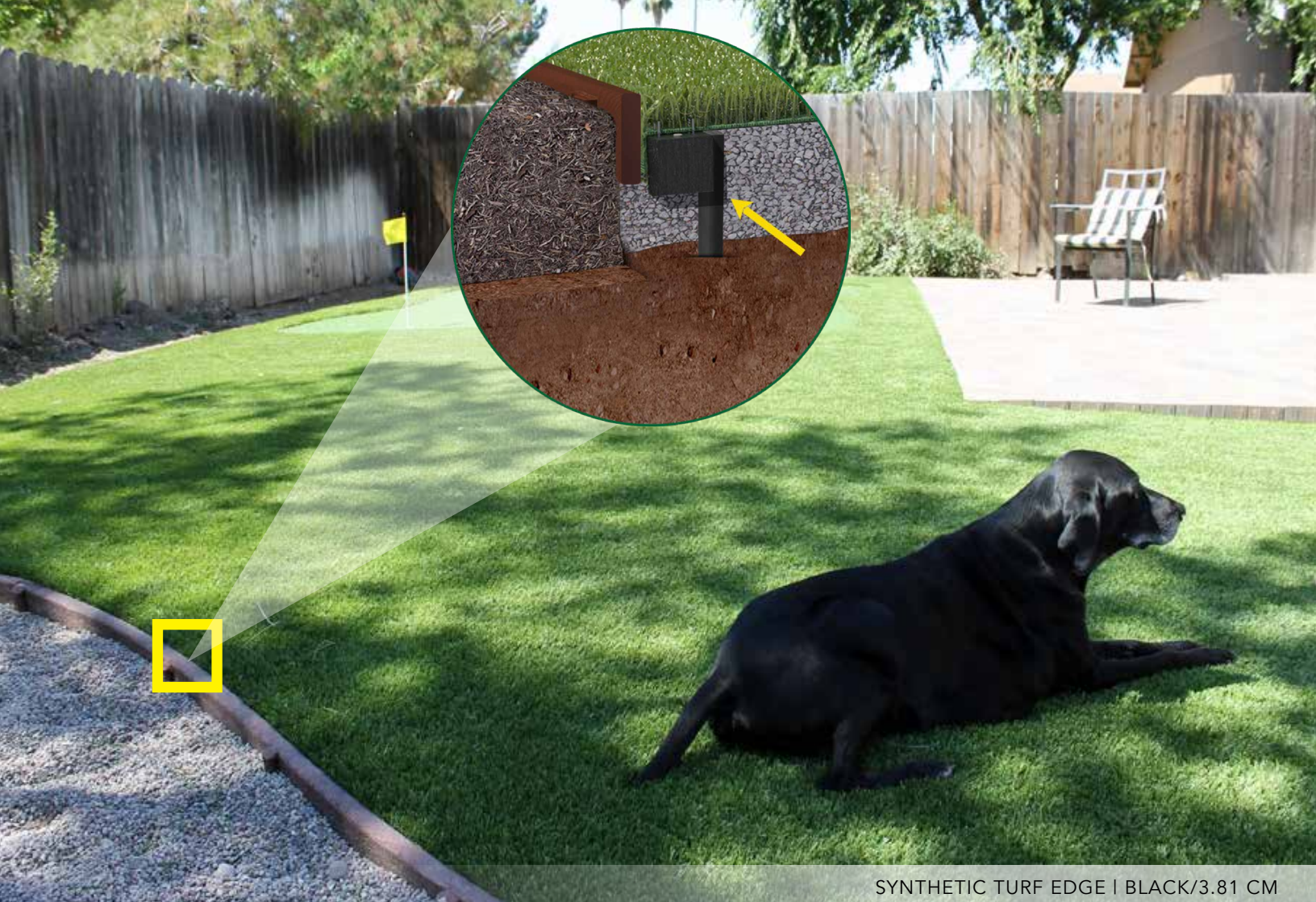

SYNTHETIC TURF EDGE | BLACK/3.81 CM

PRODUCT SPECS

| PRODUCT # | AVAILABLE SIZES <small>(Metric / Actual / Nominal Size)</small> | MIN. ORDER |
|-----------|---|------------------------|
| 100048028 | 3.81 cm x 3.81 cm x 3.65 m <small>(1.5 in x 1.5 in x 12 ft / 2x2x12)</small> | 200 pcs-2,400 ft/ lift |



SYNTHETIC TURF EDGE | BLACK/3.81 CM

SYNTHETIC TURF EDGE | FOR MAXIMUM FLEXIBILITY

Epic Plastics' Synthetic Turf Edge offers a unique exposed border or hidden anchoring solution that allows a natural edge, simplifying the artificial grass installation process and adding durability to any synthetic or artificial grass installation.

AVAILABLE COLOR:



BLACK

INSTALLATION INSTRUCTIONS

SYNTHETIC TURF EDGING DETAIL # 315-A

EPIC EDGE IS INTENDED FOR NON-STRUCTURAL USE ONLY

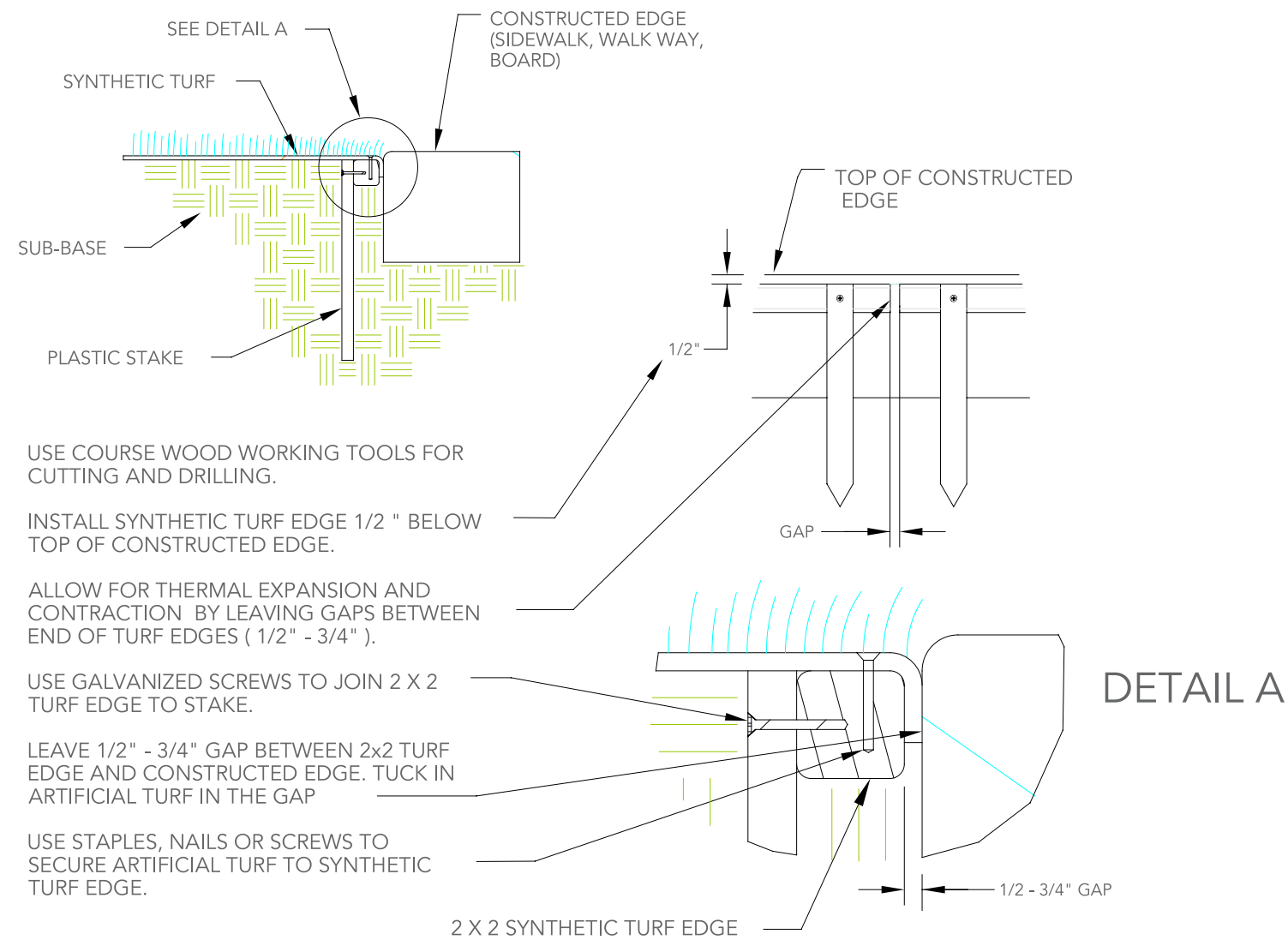

INSTALLATION INSTRUCTIONS

SYNTHETIC TURF EDGING DETAIL # 315-A

EPIC EDGE IS INTENDED FOR NON-STRUCTURAL USE ONLY

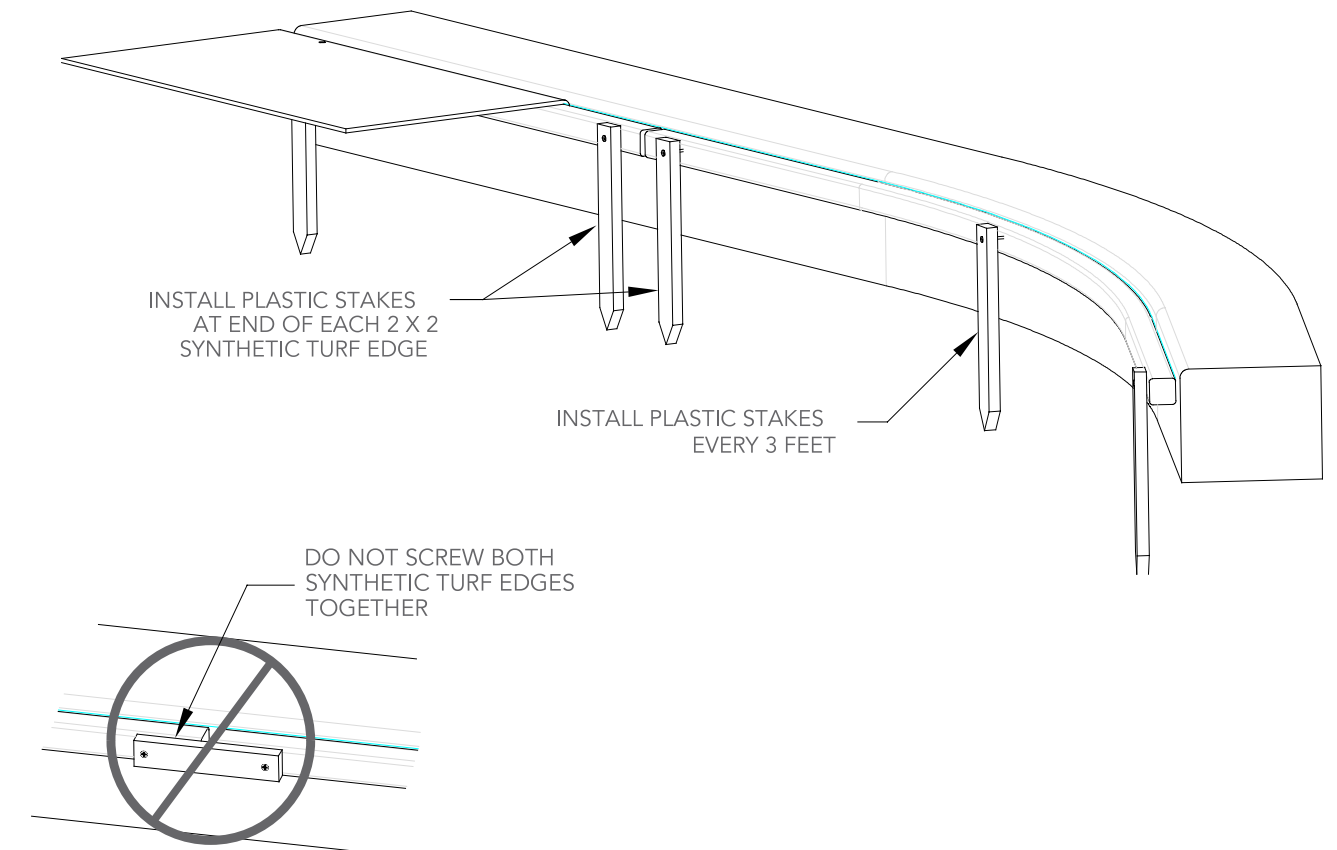

| NOMINAL DESCRIPTION | PRODUCT NUMBER | COLOR | ACTUAL DIMENSION D x H x L | MINIMUM BEND RADIUS | GAP |
|---------------------|----------------|-------|---|---------------------|-------------|
| 2 x 2 x 12 | 100048028 | BLACK | 1.50in x 1.50in x 12ft 3.81cm x 3.81cm x 3.65m | 36" | 1/2" - 3/4" |



SCAN THE QR CODE TO WATCH OUR VIDEO FOR INSTALLATION INSTRUCTIONS AND OTHER IMPORTANT RESOURCES.

Made in USA by Epic Plastics
104 E. Turner Road, Lodi, CA 95240
209-333-6161 | epicplastics.com

ACCESSORIES

| PRODUCT # | PRODUCT NAME | AVAILABLE SIZES (Metric / Actual / Nominal Size) | MIN. ORDER |
|---|--------------|--|-----------------------|
|  | 100036740 | Plastic Redwood Stake 1.7 cm x 29.84 cm x 3.5 cm (.67 in x 11.75 in x 1.38 in / 12) | 100 cnt / box |
| | 100036741 | Plastic Redwood Stake 1.7 cm x 45.08 cm x 3.5 cm (.67 in x 17.75 in x 1.38 in / 18) | 100 cnt / box |
| | 100078300 | Plastic Black Stake 1.7 cm x 29.84 cm x 3.5 cm (.67 in x 11.75 in x 1.38 in / 12) | 100 cnt / box |
| | 100082779 | Plastic Black Stake 1.7 cm x 45.08 cm x 3.5 cm (.67 in x 17.75 in x 1.38 in / 18) | 100 cnt / box |
| | 100046315 | Plastic Carmel Brown Stake 1.7 cm x 29.84 cm x 3.5 cm (.67 in x 11.75 in x 1.38 in / 12) | 100 cnt / box |
| | 100036742 | Plastic Sand Stake 1.7 cm x 29.84 cm x 3.5 cm (.67 in x 11.75 in x 1.38 in / 12) | 100 cnt / box |
|  | 200079367 | Steel J Stake Redwood 3.42 cm x 32.38 cm x 3.25 cm (1.35 in x 12.75 in x 1.28 in / 12) | 100 cnt / box |
| | 200079371 | Steel J Stake Sand 3.42 cm x 32.38 cm x 3.25 cm (1.35 in x 12.75 in x 1.28 in / 12) | 100 cnt / box |
| | 200079370 | Steel J Stake Redwood 3.81 cm x 27.94 cm x 4.44 cm (1.5 in x 11 in x 1.75 in / 12) | 100 cnt / box |
| | 200102712 | Steel J Stake Black 3.42 cm x 32.38 cm x 3.25 cm (1.35 in x 12.75 in x 1.28 in / 12) | 100 cnt / box |
|  | 100096734 | Pre-drilled Stake Black 1.7 cm x 29.84 cm x 3.5 cm (.67 in x 11.75 in x 1.38 in / 12) | 100 cnt / box |
| | 200102648 | Pre-drilled Stake Teak 1.7 cm x 29.84 cm x 3.5 cm (.67 in x 11.75 in x 1.38 in / 12) | 100 cnt / box |
| | 200102649 | Pre-drilled Stake Teak 1.7 cm x 45.08 cm x 3.5 cm (.67 in x 17.75 in x 1.38 in / 18) | 100 cnt / box |
|  | 200079368 | Steel Hairpin 3.5 mm x 33.02 cm x 3.17 cm (.14 in x 13 in x 1.25 in / 12) | 100 ea / bundle |
| | 200079369 | Steel Hairpin 4 mm x 33.02 cm x 4.57 cm (.16 in x 13 in x 1.8 in / 12) | 100 ea / bundle |
|  | 200079375 | #6 Galvanized Screws 1 1/4" | (one lb box) 12 boxes |
| | 200079376 | #6 Galvanized Screws 2" | (one lb box) 12 boxes |

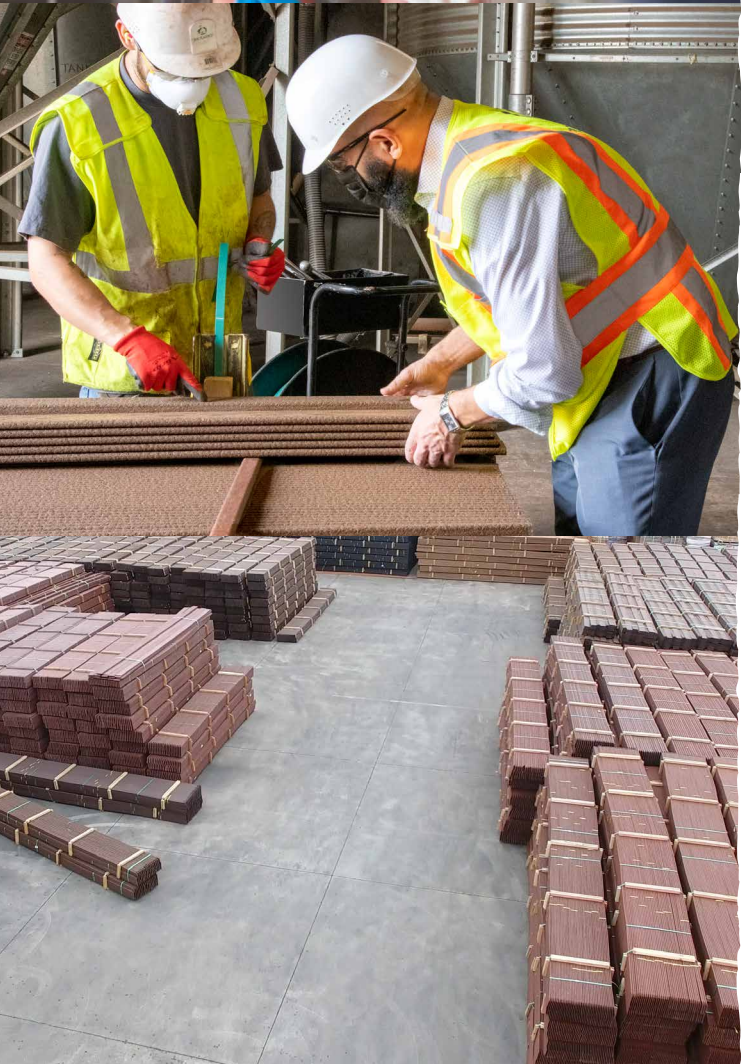

OUR RECYCLING STORY

Since 1997 Epic Plastics has set the standard for recycling in California, creating high quality and environmentally friendly landscape products from post consumer recycled plastics. Epic Plastics converts over 150 million shampoo, milk and other HDPE #2 bottles into premier products, including recycled Benda Board®, diverting over 15 million pounds of post consumer plastic from international landfills each year. Epic Plastics produces over 11 miles of Benda Board® daily and continues to set the standard for landscape edging products.

Landscape contractors and homeowners can find Epic Plastics' products in over 750 professional landscape and irrigation supply houses throughout the United States.

Epic Plastics is a division of Basalite Concrete Products, a subsidiary of the Pacific Coast Building Products family of companies.

THE PROCESS





BENDA BOARD® | REDWOOD/3.47 CM



RECYCLED LANDSCAPE EDGING

104 E Turner Road
Lodi, California 95240
(209) 333-6161

PROUDLY MADE IN THE USA EXCLUSIVELY WITH RECYCLED PLASTIC

A Division of Basalite Building Products, LLC